

BIOGAS PRE-TREATMENT PLANT

SYSAV, MALMÖ, SWEDEN

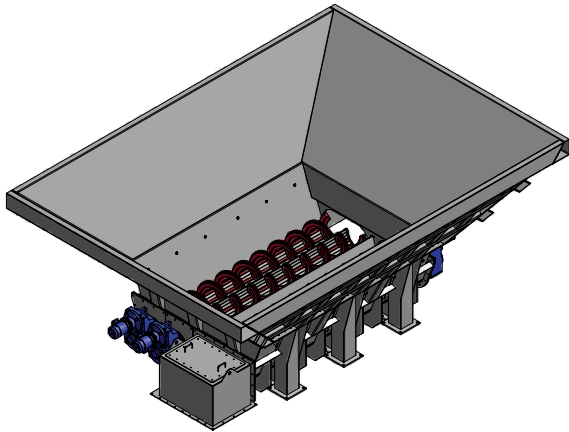

APPLICATION DETAILS

Goodtech was entrusted with the delivery and installation of a receive and pre-treatment organic waste solution for biogas production at SYSAV in Malmö. The overall goal is to maximize recycling of material to energy and reduce the amount of landfill to a minimum.

THE CHALLENGE

Goodtech assigned SPIRAC to provide a 45 m³ live bottom receiving bin as well as ten shaftless spiral conveyors used for the transport of food waste to and from waste equipment. The plant is designed to treat up to 16 tons of separated food waste per hour. The equipment for receiving and transporting organic waste was delivered in autumn 2014 and has been running since the beginning of 2015.

SPIRAC PRODUCTS USED

1. Live-bottom receiving bin 45m³
2. 4 x Live-bottom shaftless screws
3. 7x Shaftless screw conveyors

